

Specification Approval Sheet

Model: L92UMX

Prepared By/Date	Checked By/Date	Approved By/Date
Claudia		

Customer Approval	Confirmation	Date

1. Scope

This specification is suitable for the performance of the ULTRA MAX Lithium Iron Disulfide battery.

2. Model

L92UMX

3. Reference Document

IEC60086-4: 2000 Primary batteries-Part 4: Safety of lithium batteries

4. Specification

No.	Items	Specification
1	Nominal Voltage	1.5 V
2	Rated Capacity	1100 mAh
3	Working Voltage	1.30V @ 100mA discharge
4	Max. Discharge Current	1000 mA continuous
5	Discharge Cut-off Voltage	0.80V
6	Volume	3.8 cubic centimeters
7	Weight	Approx. 7.2±0.5g
8	Lithium Content	Less than 0.5 gram per cell
9	Dimensions	Diameter: 10.0±0.5 mm
		Height: 43.9±0.6 mm
10	Operating Temp.	-20 °C to 60 °C
11	Storage Temp.	-20 °C to 40 °C
12	Storage Humidity	≤75 %
13	Shelf life	10 Years

5. Test Conditions and Performance

5.1 Measuring Instrument or Apparatus

5.1.1 Dimension Measuring Instrument

The dimension measurement shall be implemented by calipers with equal or better

precision than 0.01 mm.

5.1.2 Voltmeter

Standard class specified in the national standard or a more sensitive type having input impedance of more than 10 k Ω /V.

5.1.3 Ammeter

Standard class specified in the national standard or a more sensitive type. Total external resistance including ammeter and wire should be less than 0.01 Ω .

5.2 Standard Test Conditions

Unless other defined, test and measurement shall be done under temperature of 20 \pm 5 $^{\circ}$ C and relative humidity of 45~85%.

5.3 Basic Characteristics

No.	Item	Measuring Procedure	Criteria
1	Open-Circuit Voltage	The open-circuit voltage shall be measured by voltmeter.	≥ 1.72 V
2	Dimension	Use calipers test cell's dimensions.	As in paragraph 4 item 9
3	Discharge Capacity	The capacity means the discharge capacity of the cell, which is measured by continuously discharging with a constant current of 300 mA to 0.8V.	≥ 1100 mAh
4	External Short Circuit	Positive and negative of fresh battery are connected by a Cu wire. This short-circuit condition is continued for 1 day at room temperature (20 \pm 2 $^{\circ}$ C).	No leakage; No explosion.
5	Forced Discharge	Discharged to 0.8V at 300mA; And then the sample cell is forced discharged with 300mA for 3 hours.	No explosion; No fire

5.4 Mechanical Characteristics

No.	Item	Test Method	Criteria
1	Impact	A 15.8 mm diameter bar is vertically placed across the centre of the sample cell. A 9.1 kg mass is dropped from a height of 61cm onto the sample.	No explosion, No fire
2	Vibration	Freq: 10~55hz; Amp: 2mm; Three directions; total 90 min	No leakage, No explosion, no fire 0.02V total maximum OV changes
3	Crush	A sample cell is to be crushed between two flat surfaces. Force: 32mm diameter piston; Max pressure: 17.2MPa; Max force: 13KN; Released when the max pressure obtained.	No explosion, No fire

5.5 Environmental test

No.	Item	Test Conditions	Criteria
1	Thermal test	Fresh batteries, store at 70 deg. C for 4hs; 20 deg. C for 2hs; -20 deg. C for 4hs; 20 deg. C for 2hs. All cycled 5 times	No leakage No explosion; No fire
2	Heating test	Fresh battery is heated in an oven. The rate of temperature raised: $5 \pm 2^{\circ}\text{C}$ per minute; Max. temperature $150 \pm 2^{\circ}\text{C}$ remaining for 10 minutes.	No explosion; No fire
3	Drop test	Fresh batteries; Height: 1m, 6 times; Each direction two times; Concrete floor	No leakage; No explosion; No fire

5.6 Visual inspection

There shall be no such defect as scratch, flaw, crack, and leakage, which may adversely affect commercial value of cell.

6. Drawing (unit: mm(inches))

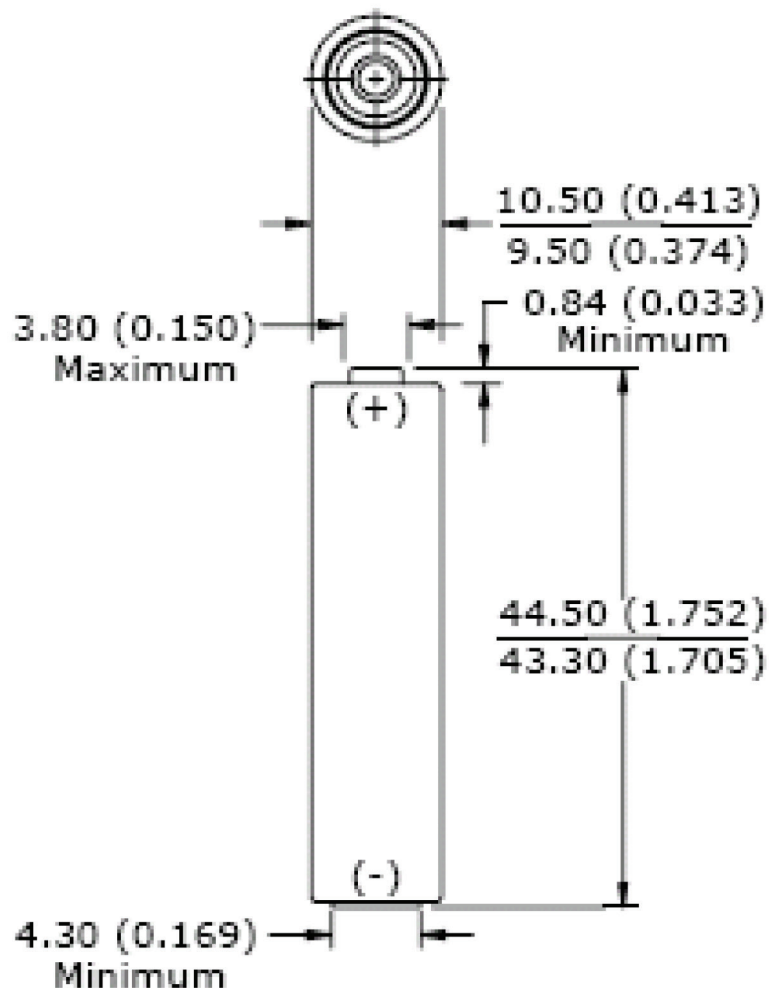

7. Discharge curve

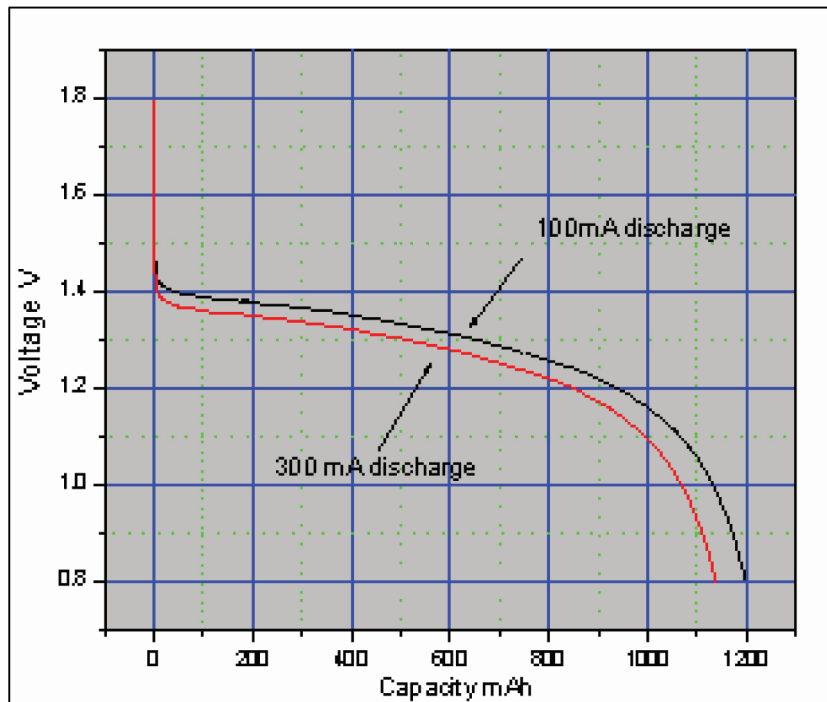

8. Cautions in use

To ensure proper use of the battery please read the manual carefully before using it.

. Handling

- ⓪ Do not expose to, or dispose of the battery in fire.
- ⓪ Do not insert with wrong polarity.
- ⓪ Do not short circuit the battery
- ⓪ Avoid excessive physical shock or vibration.
- ⓪ Do not disassemble or deform the battery.
- ⓪ Do not immerse in water.
- ⓪ Do not mix L92UMX with other different makes, type, or models of batteries.
- ⓪ Keep out of the reach of children.

. Storage

- ⓪ Store the battery in a cool, dry and well-ventilated area.

. Disposal

- ⓪ Regulations vary for different countries.
- ⓪ Dispose of in accordance with local regulations.

9. Battery operation instruction

9.1 Discharging current

Do not exceed maximum discharge current. It can cause capacity loss and excessive heating.

9.2 Operating temperature

Use battery at the operating temperature for optimum performance.

9.3 Storing the Batteries

Store the battery as per specifications. Elevated temperature causes excessive capacity loss and self discharge.

10. Period of Warranty

The period of warranty is one year from the date of shipment. Ultra Max guarantees to give a replacement in case of cells with defects due to manufacturing process.

11. Other Chemical Reaction

Because batteries utilize a chemical reaction, battery performance will deteriorate over time if stored for a long period of time without being used. In addition, if the various usage conditions such as discharge, ambient temperature, are not maintained within the specified ranges the life expectancy of the battery may be shortened or the device in which the battery is used may be damaged by electrolyte leakage. Do not leave discharge batteries in equipment.